

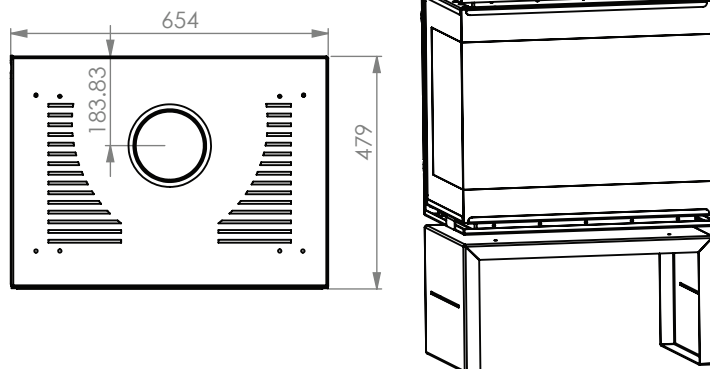

TECHNICAL DRAWING

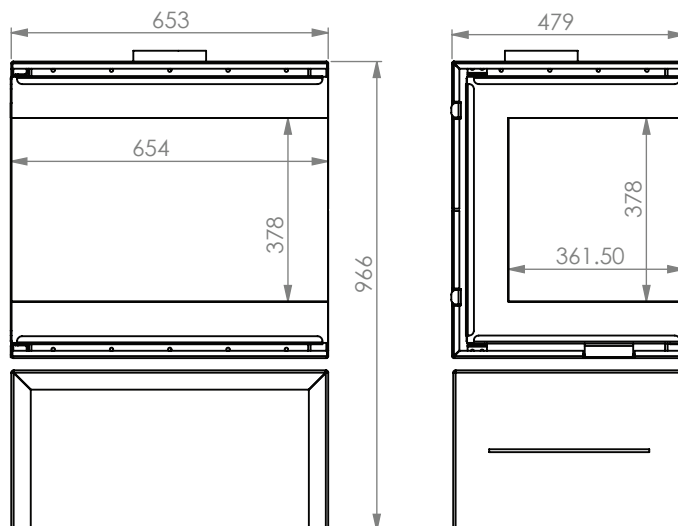

TECHNICAL SPECIFICATION

WEIGHT	100 KG
POWER	7-12 KW
EFFICENCY	>80%
CONSUME	2 - 3.5 kg/h
FLUE GAS TEMPERATURE	230 ° C
PIPE DIAMETER	Ø 150/180 mm
CO	<1500 mg m ³
WARRANTY	5 years

DIMENSIONS

Height	966 mm
Depth	479 mm
Width	653 mm